

THESE DRAWINGS ARE THE PROPERTY OF QUALTEK ELECTRONICS AND NOT TO BE REPRODUCED FOR OR COMMUNICATED TO A THIRD PARTY WITHOUT THE EXPRESS WRITTEN PERMISSION OF AN OFFICER OF QUALTEK ELECTRONICS.

1. PHYSICAL DIMENSIONS

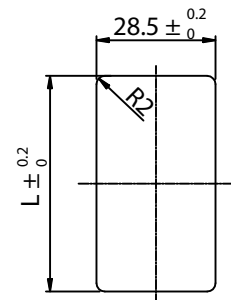
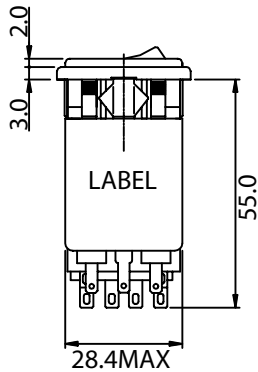
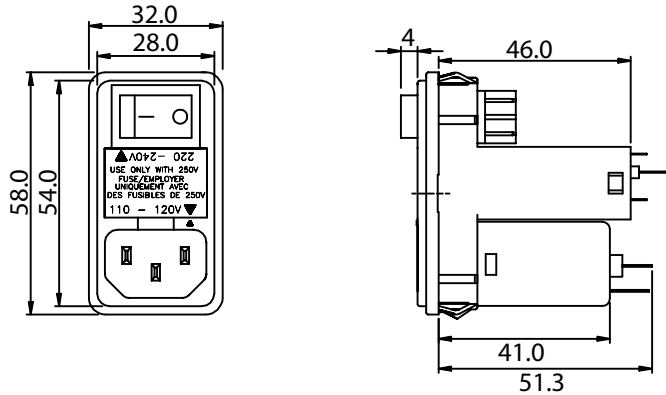

PANEL CUTOUT  
(MOUNTING FROM FRONT)  
L ACCORDING TO PANEL THICKNESS  
0.8~2.0mm L=55.9  
2.1~3.2mm L=56.2

2. ELECTRICAL SCHEMATIC

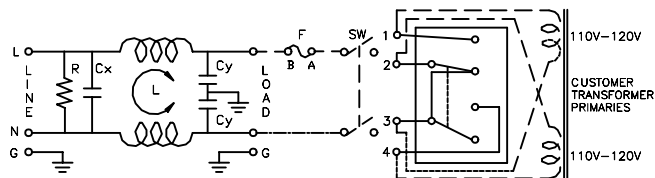

L: 2.5mH  
Cx: 0.1uF  
Cy: 2200pF  
R: 1.0MΩ

| REVISION |                 |          |          |
|----------|-----------------|----------|----------|
| REV.     | DESCRIPTION     | DATE     | APPROVED |
| B        | RoHS Compliancy | 06-01-06 | DP       |
|          |                 |          |          |

ELECTRICAL CHARACTERISTICS:

- 1-1. VOLTAGE RATING.....115/250VAC
- 1-2. CURRENT RATING  
A. @ 115 VAC.....10 A RMS MAX  
B. @ 250 VAC.....10 A RMS MAX
- 1-3. OPERATING FREQUENCY.....50/60Hz
- 1-4. LEAKAGE CURRENT: EACH LINE TO GROUND  
A. @ 115 VAC 60Hz.....0.20 mA MAX  
B. @ 250 VAC 50Hz.....0.40 mA MAX
- 1-5. HIPOT RATING (FOR ONE MINUTE)  
A. LINE TO GROUND.....2250 VDC  
B. LINE TO LINE.....1450 VDC
- 1-6. MINIMUM INSERTION LOSS IN dB: (AT 50 OHM SYSTEM)

| FREQ. MHz    | .01 | .05 | .10 | .15 | .50 | 1.0 | 5.0 | 10 | 30 |
|--------------|-----|-----|-----|-----|-----|-----|-----|----|----|
| COM. MODE dB | /   | /   | /   | 3   | 8   | 10  | 20  | 30 | 45 |
| DIF. MODE dB | /   | /   | /   | 5   | 12  | 15  | 30  | 30 | 40 |

- 1-7. OPERATING TEMPERATURE.....-25° TO +85°
- 1-8. SAFETY:
- 2-0. RoHS COMPLIANT

**CONTROLLED**

| Dim range (mm) | Tolerance +/- (mm) | Qualtek Electronics Corp.<br>PPC DIVISION |                |                 |
|----------------|--------------------|---|----------------|-----------------|
|                |                    | Part Number: 882-10/018                   |                |                 |
| 0-1            | 0.15               | Description: EMI FILTER                   |                |                 |
| 1-6            | 0.20               |   | UNIT: mm       | REV. B          |
| 6-18           | 0.30               |   |                |                 |
| 18-50          | 0.50               |   |                |                 |
| 50-120         | 0.70               | Drawn / Date                              | Checked / Date | Approved / Date |
| 120-250        | 0.90               | B.ZHANG<br>04-07-03                       | 04-07-03       | JJH / 04-07-03  |
| 250-500        | 1.20               |   |                |                 |